

1 Description

The CN71102 is a dedicated chip for zero crossing detection circuits, which realizes the detection function by monitoring the input voltage. When the input voltage is less than the threshold, the optocoupler is driven to obtain a zero crossing detection signal, which is provided to the application control system, and when the input voltage is greater than the threshold, the output shows a high resistance state. The chip has a very low power consumption, with a quiescent current of less than 1 μ A, so a large portion of the power is used to drive the optocoupler to obtain a wider zero crossing detection pulse for system identification. The chip's VIN pin is designed as a Schmitt trigger with a high level threshold of 2.15 V and a low level threshold of 0.95 V. The internal hysteresis feature helps to filter out burrs on the power line and avoid false zero crossing detection signals caused by noise. In addition, the CN71102 integrates a rectifier diode for the power supply of the chip and optocoupler, and a regulator diode on the input side, so that only one capacitor is needed to rectify the input voltage and supply power to the IC and optocoupler, and the whole solution requires only a few peripheral devices.

The CN71102 is available in SOT23-3 package.

2 Features

- Low power consumption, quiescent current <math><1\mu\text{A}</math>
- High detection accuracy
- Effective power line noise filtering
- Integrated rectifier diode
- Integrated voltage regulator diode
- Few peripheral components

3 Applications

- Power Carrier Communications
- Household Appliances
- Power Device Access
- RGB lighting control synchronization

4 Pinout

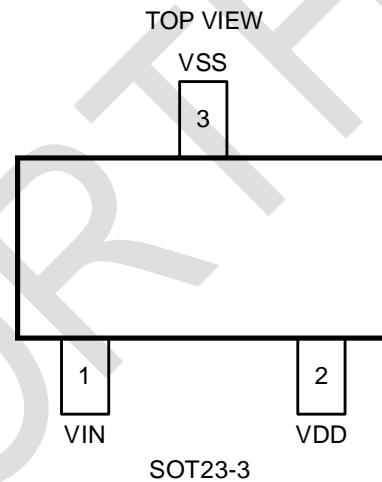

5 Ordering information

Product Number	Package	Quantity/Tape
CN71102	SOT23-3	3000/Tape

6 Marking

Product Number	Marking
CN71102	02YW

Note: YY=Year WW=Week.

Green (RoHS & HF): CHIPNORTH defines "Green" to mean Pb-Free (RoHS compatible) and free of halogen substances. If you have additional comments or questions, please contact your CHIPNORTH representative directly.

Moisture sensitivity level(MSL):3

7 Typical Application

The CN71102 can achieve zero crossing detection through the circuit shown in Figures 1 and 2. In the circuit, C1 is used as an energy storage capacitor to supply power to the chip and optocoupler, with a typical value of 56nF and a maximum of 100nF. The resistance value of voltage divider resistors R1~R4 can be adjusted according to the AC input voltage, with a typical value of 750K. R5 is recommended to be 4.7K, R6 is recommended to be 10-20K, and C2 is recommended to be 1nF. The built-in regulator diode in the VIN port has a typical regulator value of 5.9V.

When the input voltage VIN is higher than the threshold VTH, the internal rectifier circuit will charge C1 to VDD, to complete the energy storage; when VIN is lower than VTH, the AC input is close to or at the point of zero crossing, the VDD to VSS discharge circuit begins operation, the energy stored in the C1 through the photocoupler light-emitting diode to release, generating zero crossing pulse. The specific waveform is shown in Figure 3.

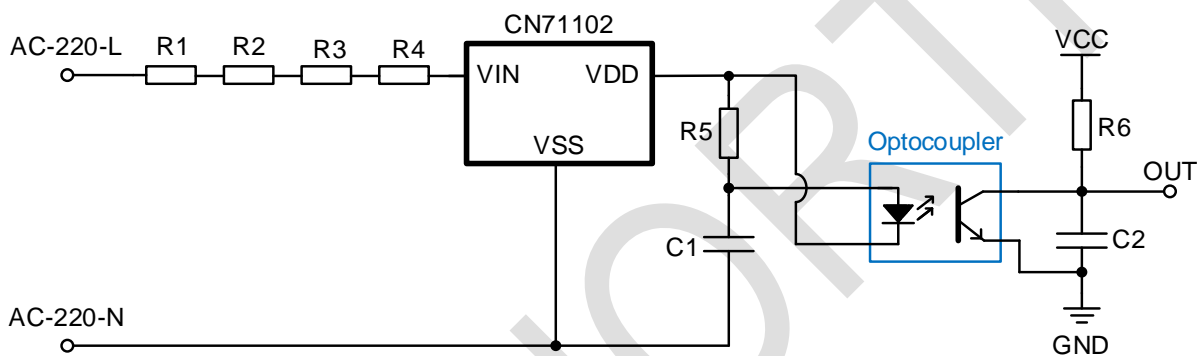

Figure 1 Falling edge zero crossing detection application

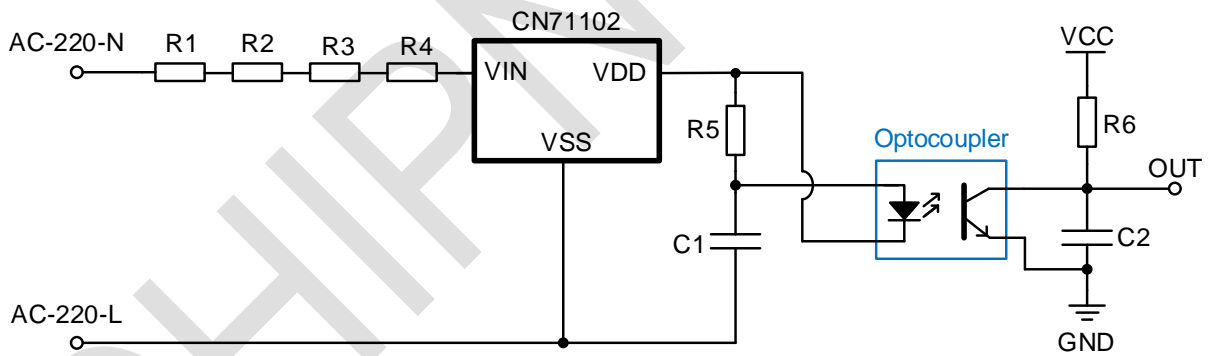

Figure 2 Rising edge zero crossing detection application

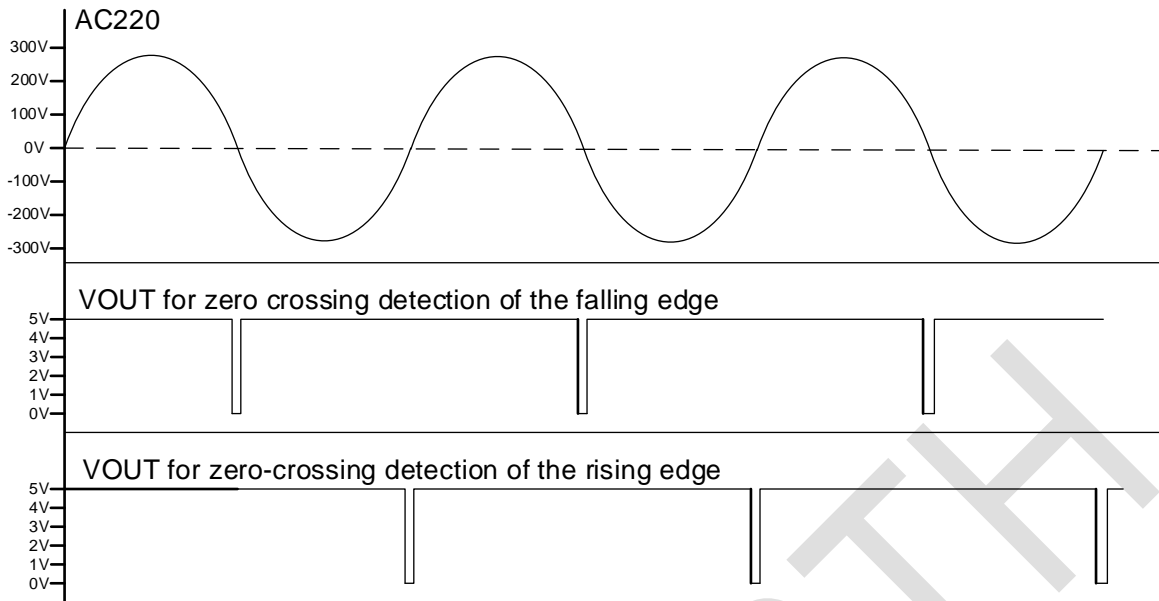

Figure 3 220V AC zero crossing detection waveforms

8 Pin Descriptions

Pin No.	Pin Name	Descriptions
1	VIN	Detection input
2	VDD	Power supply, connect the negative end of the optocoupler light-emitting diode
3	VSS	GND

9 Specifications

9.1 Absolute Maximum Ratings

Parameter	Value	Units
Input Voltage	0~7	V
VDD Voltage	-0.5~+7	V
Storage Temperature Range	-55~+150	°C
Soldering Temperature	260 (soldering 10s)	°C

(1) Stresses exceeding the values listed under Absolute Maximum Ratings may cause permanent damage to the device. These listed values are stress ratings only and do not imply that the device will operate properly under these conditions or any other conditions other than the recommended operating conditions. Prolonged operation at maximum absolute rating conditions can affect device reliability.

(2) All voltage values are based on the ground terminal.

9.2 ESD Ratings

Discharge mode	Standard	Value	Units
HBM	ANSI/ESDA/JEDEC JS-001-2024	±8000	V
CDM	ANSI/ESDA/JEDEC JS-002-2022	±2000	V
Latch up	JESD78F.02-2023	±800	mA

9.3 Recommended Operating Range

Parameter	Symbol	Min.	Max.	Units
Input Voltage	V _{IN}	3	5.5	V
Operating Temperature	T _A	-40	105	°C

9.4 Thermal Information

Parameter	Package	Value	Unit
Junction to ambient thermal resistance (R _{θJA})	SOT23-3	300	°C/W

9.5 Electrical Characteristics

Test conditions: $T_A=25^{\circ}\text{C}$, unless otherwise specified.

Parameter	Symbol	Conditions	Min	Typ	Max	Unit
Input Voltage	V_{IN}		3	5	5.5	V
Chip operating current	I_{DD1}	$V_{IN}=5\text{V}$		0.1	1	μA
	I_{DD2}	$V_{DD}=5\text{V}, V_{IN}=V_{SS}$		10		mA
Output Delay Time	T_{delay}	5V connected to 5k resistor to VDD, V_{IN} quickly drops from 5V to 0V		4		μs
Input High Level	V_{IH}			2.15	2.5	V
Input Low Level	V_{IL}		0.6	0.95		V
Input Threshold hysteresis	V_{hyst}			1.2		V

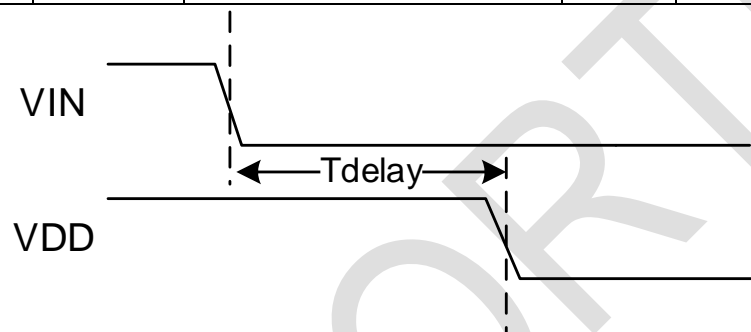

9.6 Characteristics Curve

Test conditions: $T_A=25^{\circ}\text{C}$, unless otherwise specified.

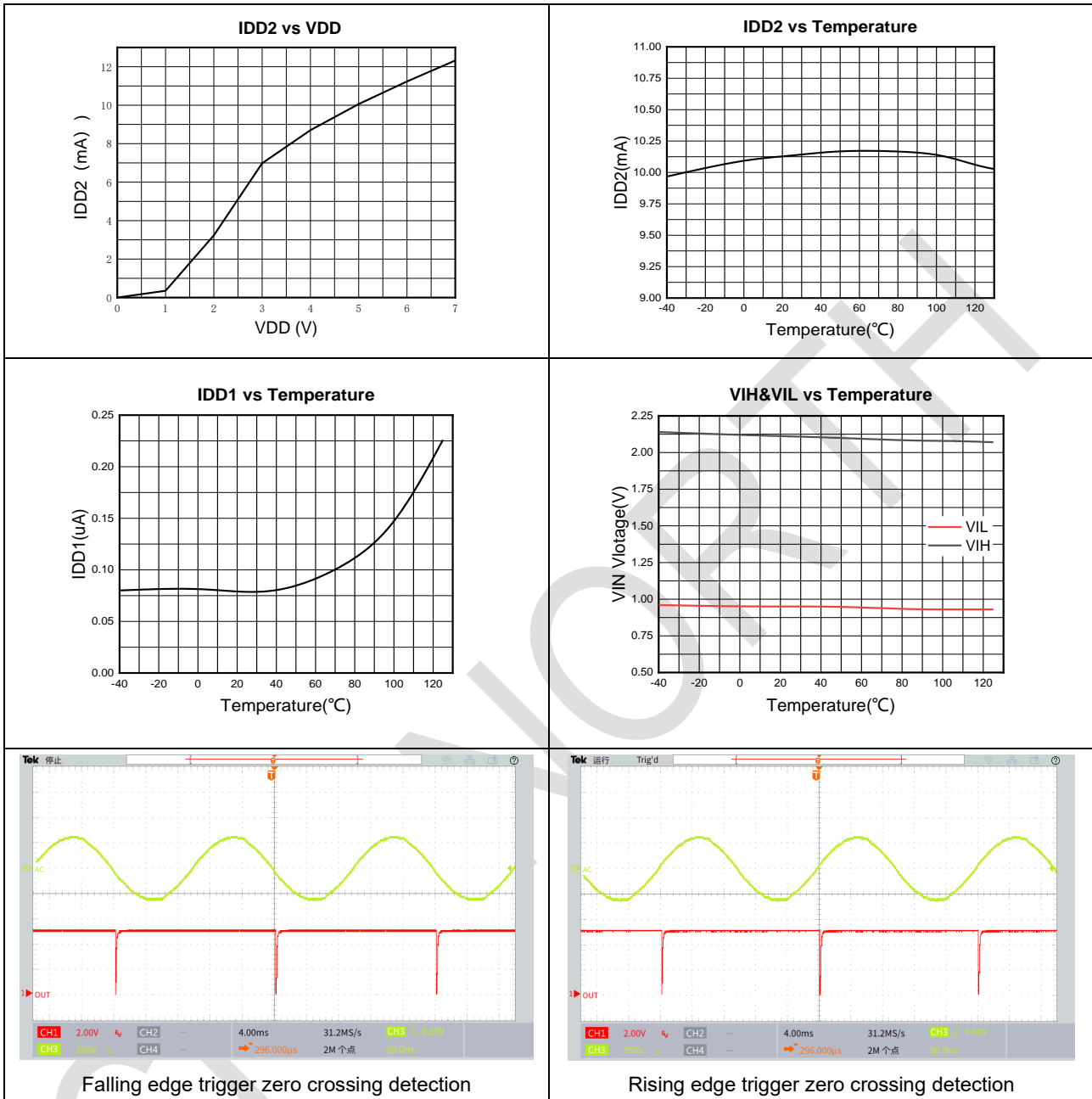

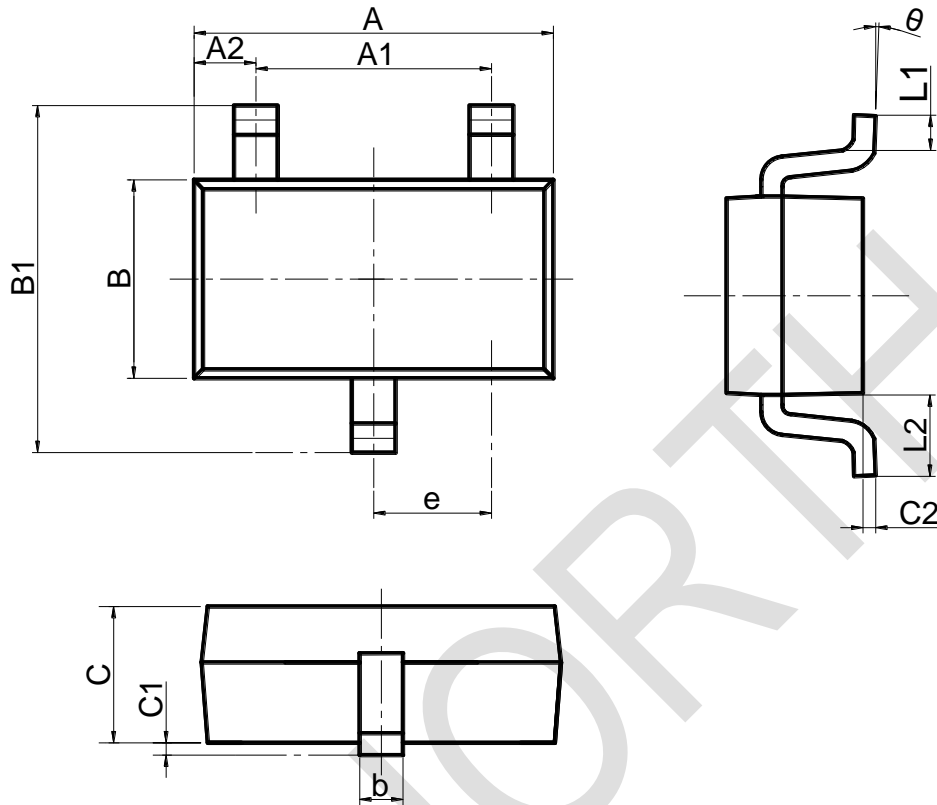
10 Package Information
SOT23-3

Symbol	Dimension	Min(mm)	Typ (mm)	Max(mm)
A		2.7	2.9	3.1
A1		1.7	1.9	2.1
A2				0.6
B		1.5	1.6	1.8
B1		2.6	2.8	3.0
e		0.85	0.95	1.05
b		0.3	0.4	0.5
C		1.0	1.1	1.2
C1				0.1
L1		0.2		
L2			0.6	
C2		0.02		0.1
θ		0°		15°

11 Important Statement

Chipnorth Electronic Technology (Nanjing) Co., Ltd. and its subsidiaries reserve the right to make modifications, improvements, corrections, or other changes to this document and to any of the products described herein at any time without notice. Chipnorth Electronic Technology (Nanjing) Co., Ltd. disclaims any liability arising out of the use of this document or any of the products described herein; Chipnorth Electronic Technology (Nanjing) Co., Ltd. does not transfer any license to its patents or trademarks or other rights. Any customer or user using this document or any of the products described herein assumes all risk and agrees to hold harmless Chipnorth Electronic Technology (Nanjing) Co., Ltd. and all companies whose products are displayed on Chipnorth Electronic Technology (Nanjing) Co., Ltd.

Chipnorth Electronic Technology (Nanjing) Co., Ltd. makes no warranty and assumes no responsibility for any products purchased through unauthorized sales channels. In the event that a customer purchases or uses a product from Chipnorth Electronic Technology (Nanjing) Co., Ltd. for any unintended or unauthorized use, the customer shall indemnify and hold harmless Chipnorth Electronic Technology (Nanjing) Co., Ltd. and its representatives from and against all claims, damages, and attorney's fees arising from any personal injury or death, directly or indirectly, arising out of or in connection with such purchase or use.