

High Precision Low Dropout Linear Regulators

1 Description

The CN84MXXX is a high precision, low dropout voltage linear regulator manufactured using the BCD process. It can supply up to 500mA output current with a quiescent current of 2.5 μ A. It has internal short circuit protection and thermal shutdown. It is available in SOT89-3, SOT89-5, DFN2X2-6, SOT23-5, SOT23-3, SOT-223, and TO-252 packages.

2 Features

- Ultra-low quiescent current: 2.5 μ A
- High accuracy: $\pm 2\%$
- Low dropout voltage: 50mV @ I_{OUT} = 100mA @ V_{OUT} = 3.3V
- Maximum Output Current: 500mA
- Input Voltage Range: Max 12V
- Enabling Control
- Output short circuit protection
- Thermal shutdown

3 Applications

- Cell phone
- Battery powered equipment
- Wireless telephone, wireless communication equipment
- Camera Recorder
- Portable audio-visual equipment
- Palmtop computer

4 Ordering information

Product Number	Package	Quantity/Tape
CN84MXXXDSR	DFN2x2-6	4000/ Tape
CN84MXXXTCR	SOT23-5	3000/ Tape
CN84MXXXTGR	SOT23-3	3000/ Tape
CN84MXXXOGR	SOT89-3	1000/ Tape
CN84MXXXAOG	SOT89-3	1000/ Tape
CN84MXXXOBR	SOT89-5	1000/ Tape
CN84MXXXMGR	SOT-223	2500/ Tape
CN84MXXXRGR	TO-252	80/ Tape

Product Number	Output voltage
CN84M018	V _{OUT} =1.8V
CN84M028	V _{OUT} =2.8V
CN84M030	V _{OUT} =3.0V
CN84M033	V _{OUT} =3.3V
CN84M036	V _{OUT} =3.6V
CN84M040	V _{OUT} =4.0V
CN84M050	V _{OUT} =5.0V

5 Marking

ProductNumber	Marking*
CN84MXXXDSR	84MXX YYWW
CN84MXXXTCR	84MXXX YYWW
CN84MXXXTGR	84MXXT YYWW
CN84MXXXOGR	84MXXX YYWW
CN84MXXXAOG	84MXXXA YYWW
CN84MXXXOBR	4MXXOBR YYWW
CN84MXXXMGR	84MXXXM YYWW
CN84MXXXRGR	CN84MXXX YYWW

Note: YY=Year WW=Week.

Green (RoHS & HF): CHIPNORTH defines "Green" to mean Pb-Free (RoHS compatible) and free of halogen substances. If you have additional comments or questions, please contact your CHIPNORTH representative directly. Moisture sensitivity level(MSL):3

6 Pinout

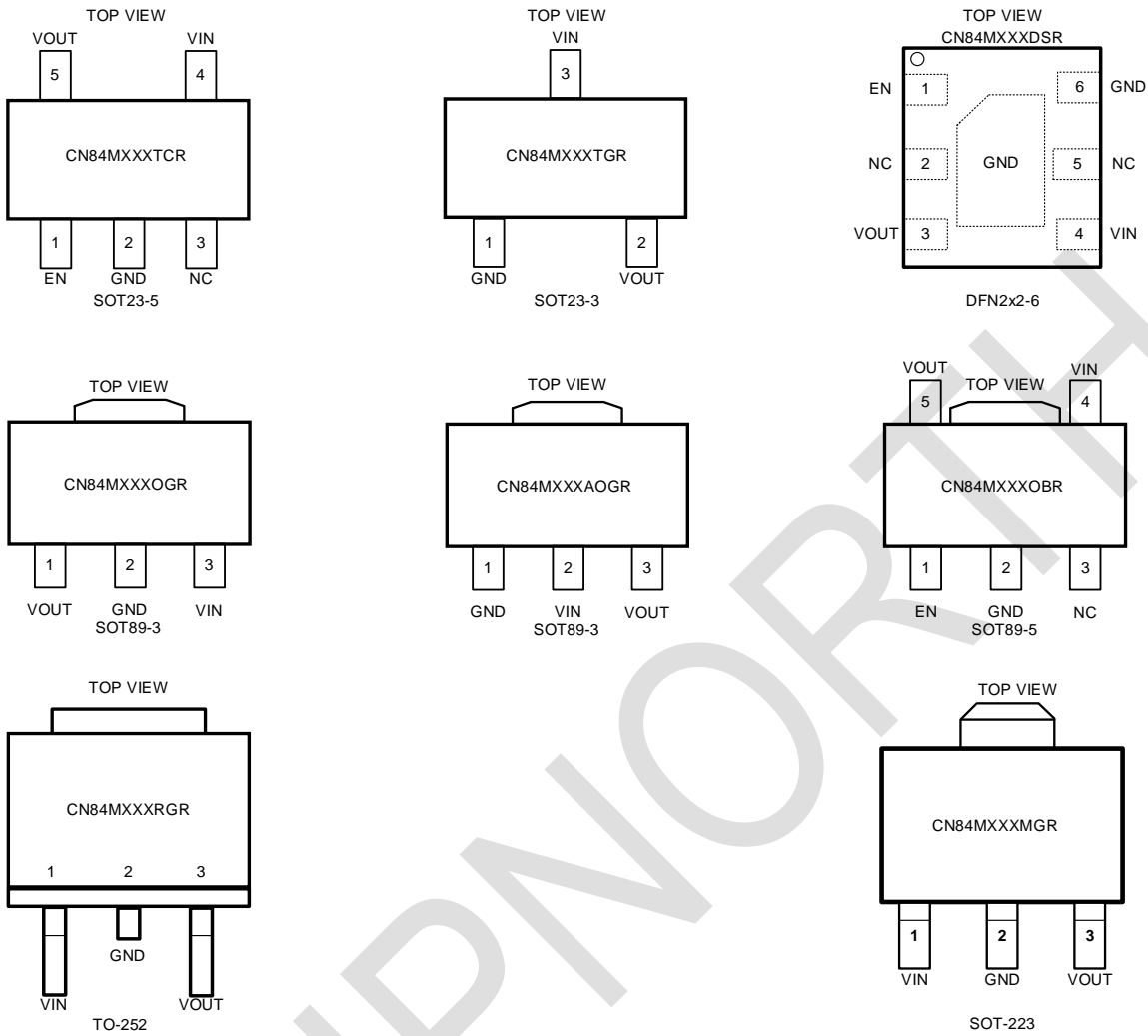

7 Typical Application

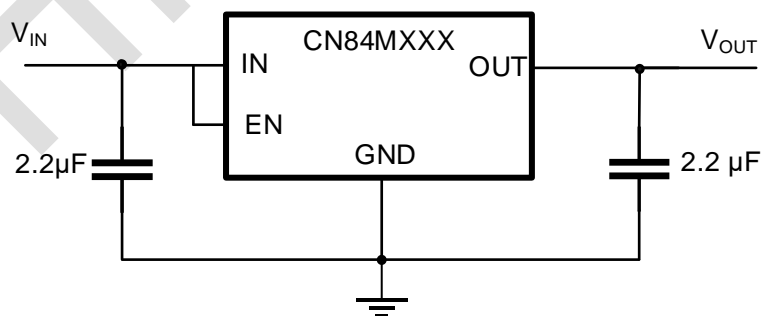

Note: General application circuits are recommended input capacitance $C_{IN} = 2.2\mu\text{F}$, near the chip input; output capacitance $C_{OUT} = 2.2\mu\text{F}$, near the chip output.

8 Block Diagram

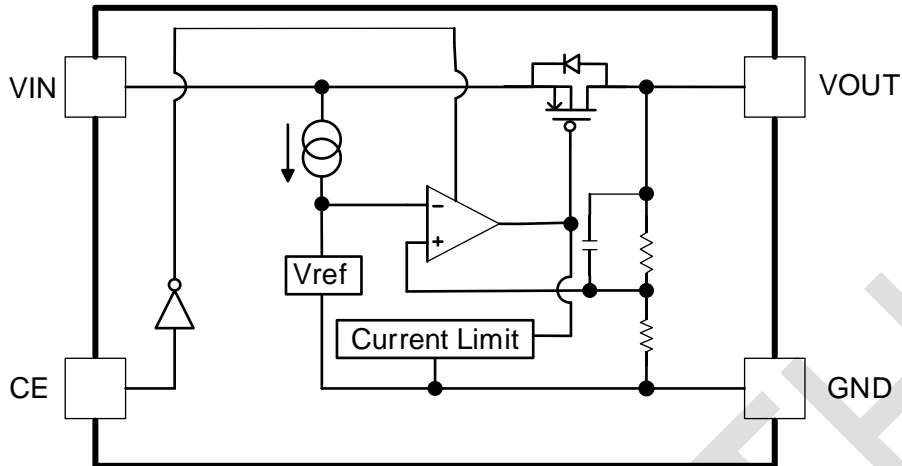

9 Pin Descriptions

Pin Name	Pin No.					Descriptions
	CN84MXXX OGR	CN84MXXX AOG R	CN84MXXX OBR	CN84MXXX RGR	CN84MXXX TCR	
GND	2	1	2	2	2	GND
VIN	3	2	4	1	4	Input
VOUT	1	3	5	3	5	Output
EN			1		1	Enable
NC			3		3	No Connect

Pin Name	Pin No.					Descriptions
	CN84MXXX TGR	CN84MXXX MGR	CN84MXXX DSR			
GND	1	2	6			GND
VIN	3	1	4			Input
VOUT	2	3	3			Output
EN			1			Enable
NC			2、5			No Connect

10 Specifications

10.1 Absolute Maximum Ratings

Parameter	Symbol	Value	Units
Maximum Input Voltage	V_{IN}	-0.3 ~ 14	V
Maximum Output Voltage	V_{OUT}	-0.3 ~ 8	V
EN enable voltage	V_{EN}	-0.3 ~ 14	V
Ambient temperature	T_A	-40 ~ 105	°C
Storage temperature range	T_{STG}	-55 ~ 150	°C
Soldering temperature	T_{LEAD}	260 (Soldering, 10s)	°C

(1) Stresses exceeding the values listed under Absolute Maximum Ratings may cause permanent damage to the device. These listed values are stress ratings only and do not imply that the device will operate properly under these conditions or any other conditions other than the recommended operating conditions. Prolonged operation at maximum absolute rating conditions can affect device reliability.

(2) All voltage values are based on the ground terminal.

10.2 ESD Ratings

Discharge mode	Standardize	Value	Units
HBM	ESDA/JEDEC JS-001-2017	±4000	V
CDM	ESDA/JEDEC JS-002-2018	±2000	V

10.3 Recommended Operating Range

Parameter	Symbol	Min.	Max.	Units
Input Voltage Range	V_{IN}	$V_{OUT}+1$	12	V
Ambient temperature	T_A	-40	105	°C

10.4 Thermal Information

Parameter	Package	Value	Units
Junction to ambient thermal resistance ($R_{\theta JA}$)	SOT23-3	220	°C/W
	SOT23-5	188	°C/W
	DFNWB-4	208	°C/W
	SOT89-3 (OGR)	100	°C/W
	SOT89-3 (AOGR)	165	°C/W
	SOT89-5	70	°C/W
	TO-252	30	°C/W
	SOT-223	62	°C/W

(1) Thermal resistance is not a fixed constant; its value is influenced by the following factors: PCB heat dissipation capacity, number and thickness of copper layers, ambient temperature, airflow velocity, etc.

(2) The thermal resistance values listed in the datasheet are provided solely for customers to compare the thermal performance of different packages. Since the heat dissipation conditions of the PCB in actual customer applications differ from those of our test boards, the actual measured thermal resistance values may vary from the nominal values in the datasheet. Customers should conduct verification on their own system boards to ensure that the thermal design meets the requirements of the product application.

10.5 Electrical Characteristics

Test conditions: $V_{IN}=V_{OUT}+1V$, $C_{IN}=2.2\mu F$, $C_{OUT}=2.2\mu F$, $T_A=25^\circ C$, unless otherwise specified.

Parameter	Symbol	Conditions	Min	Typ	Max	Units
Input Voltage Range	V_{IN}	$I_{OUT}=10mA$	$V_{OUT}+0.1V$		12	V
Output voltage *1	V_{OUT}	$V_{IN}=V_{OUT}+2V$, $I_{OUT}=10mA$	V_{OUT} $\times 0.98$	V_{OUT}	V_{OUT} $\times 1.02$	V
Output Voltage Accuracy	$V_{OUT}\%$	$V_{IN}=V_{OUT}+2V$, $I_{OUT}=10mA$	98%		102%	
Linear rate of adjustment	$\frac{\Delta V_{OUT}}{\Delta V_{IN} \cdot V_{OUT}}$	$V_{IN}=V_{SET}+1V \sim 12V$ $I_{OUT}=10mA @ V_{OUT}=3.3V$			0.1	%/V
Load Adjustment Ratio	ΔV_{OUT}	$V_{IN}=V_{SET}+1V$ $I_{OUT}=0 \sim 1A @ V_{OUT}=3.3V$		35	70	mV
Quiescent current	I_Q	$V_{IN}=12V$, $I_{OUT}=0mA$	0.8	2.5	4.2	μA
Dropout voltage *2	V_{DROP}	$I_{OUT}=100mA @ V_{OUT}=3.3V$	20	50	80	mV
Maximum Output Current	I_{OUT_MAX}		500			mA
Current Limit *3	I_{LIMIT}	$V_{IN}=V_{OUT}+1.0V$	500	720		mA
OTP threshold		95% rated V_{OUT}		160		$^\circ C$
OTP hystereis				30		$^\circ C$
PSRR		100Hz		60		dB

Note*:

*1, $V_{OUT(S)}$: output voltage when $V_{IN} = V_{OUT} + 1V$, $I_{OUT} = 1mA$.

*2, $V_{DROP}=V_{IN}-(V_{OUT_REG} \cdot 0.98)$, V_{OUT_REG} is the output voltage when $V_{IN} = V_{OUT} + 1.0V$ and $I_{OUT} = 100mA$. V_{IN} is the input voltage, and when the input voltage is gradually reduced, the output voltage becomes 98% of V_{OUT_REG} .

*3, I_{LIMIT} : Output current when $V_{IN} = V_{OUT} + 1V$ and $V_{OUT} = 0.95 \times V_{OUT(S)}$.

10.6 Characteristics Curve (CN84M050MGR)

Test conditions: $V_{IN}=V_{OUT}+1V$, $C_{IN}=2.2\mu F$, $C_{OUT}=2.2\mu F$, $T_A=25^\circ C$, unless otherwise specified.

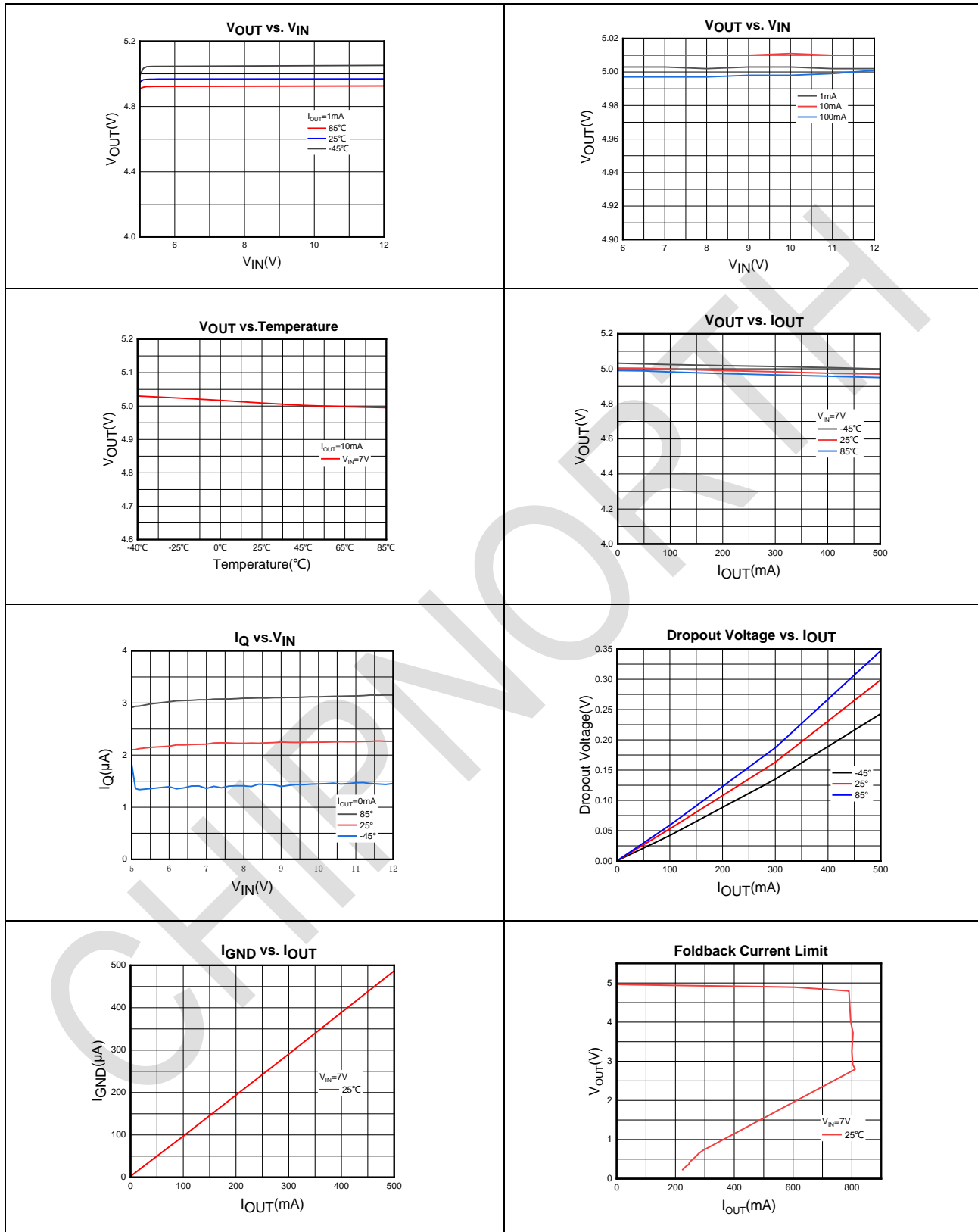

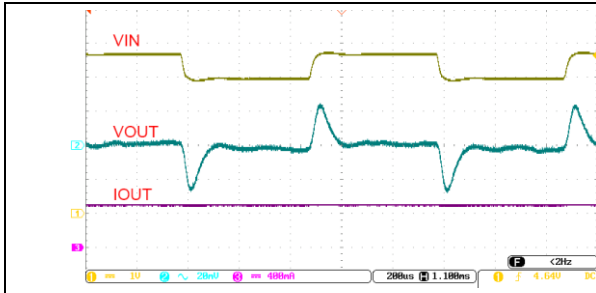

Figure 1 Line Transient
(V_{IN} =from $V_{OUT}+1V$ to $7V$ to $V_{OUT}+1V$, $I_{OUT}=0.5A$)

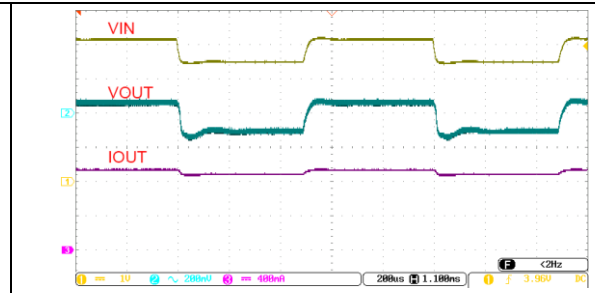

Figure 2 Line Transient
(V_{IN} =from $V_{OUT}+1V$ to $7V$ to $V_{OUT}+1V$, $I_{OUT}=1A$)

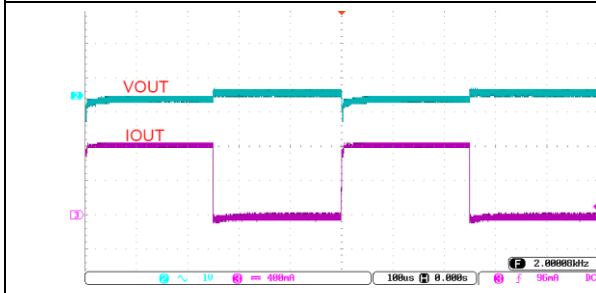

Figure 3 Load Transient
($V_{IN}=V_{OUT}+1V$, $I_{OUT}=0A-1A-0A$)

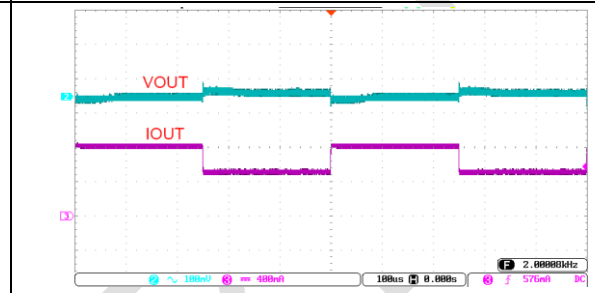
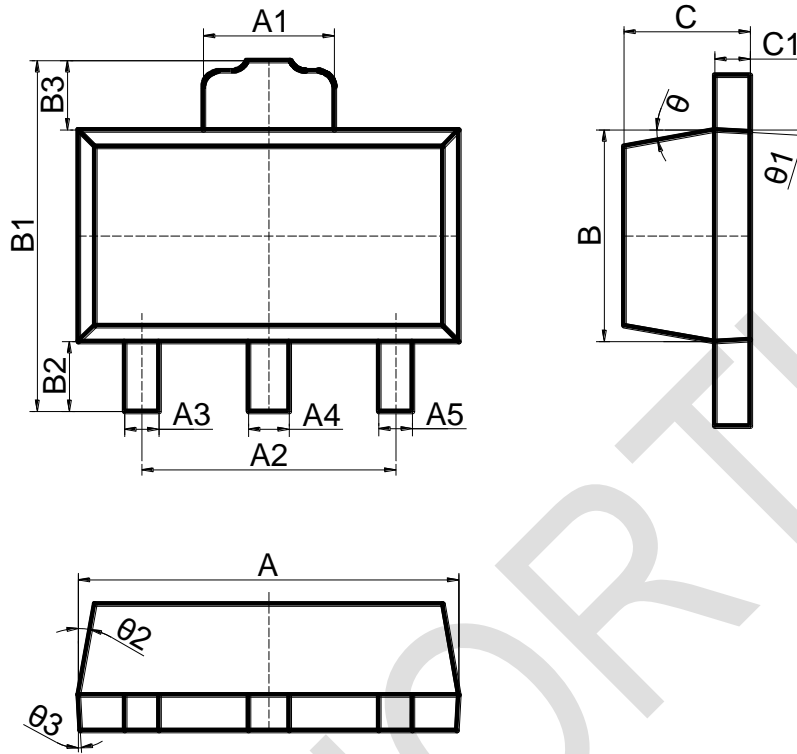

Figure 4 Load Transient
($V_{IN}=V_{OUT}+1V$, $I_{OUT}=0.5A-1A-0.5A$)

CHIPNORTH

11 Package Information

SOT89-3

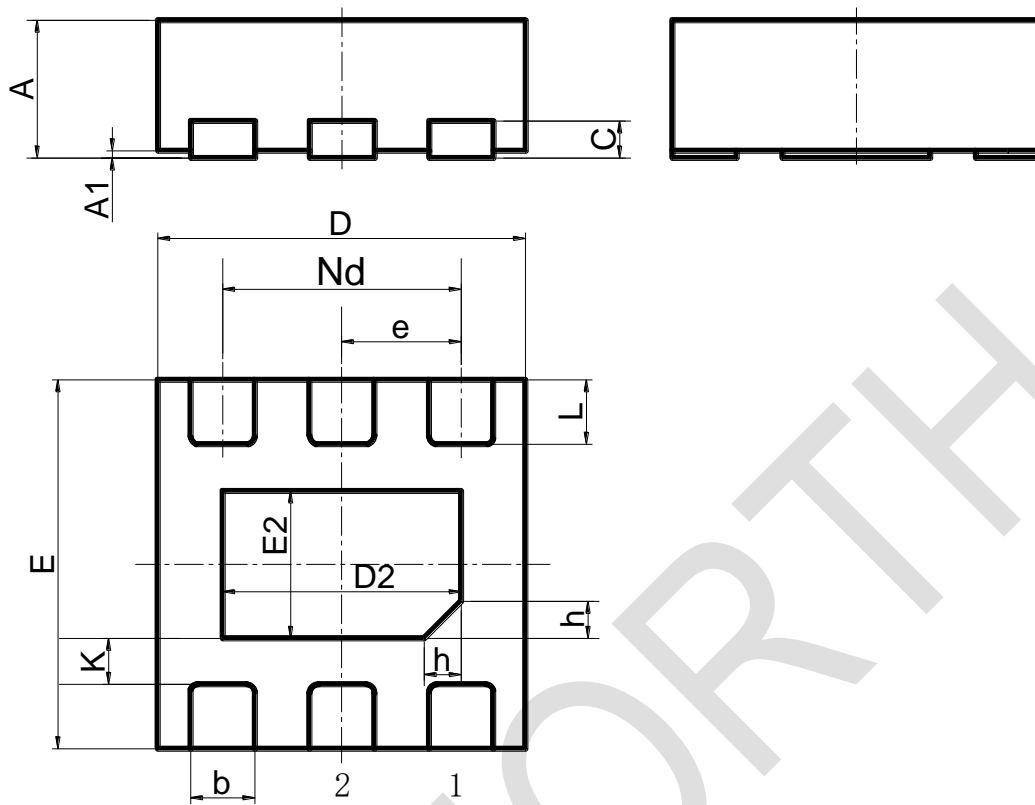

Dimension Symbol	Min (mm)	Nom (mm)	Max (mm)
A	4.4	4.5	4.6
A1	1.4	1.6	1.8
A2	2.8	3.0	3.2
A4	0.37	0.47	0.57
A5	0.22	0.42	0.62
B	2.4	2.5	2.6
B1	-	-	4.25
B2	0.8	-	-
C	1.4	1.5	1.6
C1	0.3	0.4	0.5

DFN2x2-6

Dimension Symbol	Min (mm)	Nom (mm)	Max (mm)	Dimension Symbol	Min (mm)	Nom (mm)	Max (mm)
A	0.70	0.75	0.80	E2	0.75	0.80	0.85
A1	0.00	0.02	0.05	e	0.650(BSC)		
b	0.30	0.35	0.40	Nd	1.300(BSC)		
c	0.18	0.20	0.25	K	0.20	-	-
D	1.95	2.00	2.05	L	0.28	0.33	0.38
E	1.95	2.00	2.05	h	0.15	0.20	0.25
D2	1.25	1.30	1.35				

SOT23-5

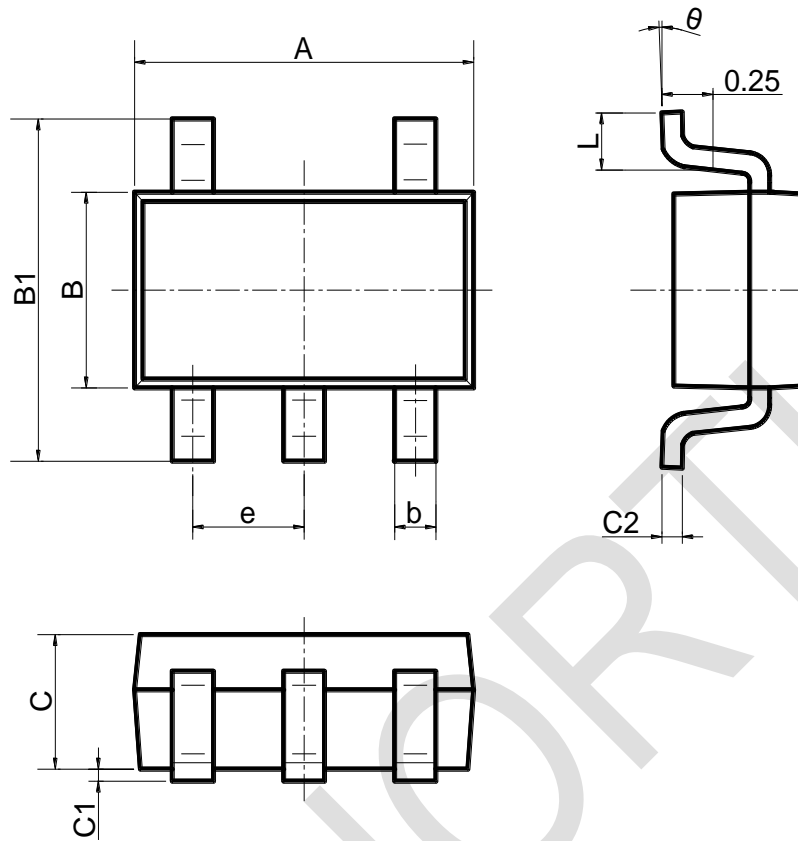

Dimension Symbol	Min (mm)	Max (mm)	Dimension Symbol	Min (mm)	Max (mm)
A	2.82	3.02mm	C	1.05	1.15
e	0.95(BSC)		C1	0.03	0.15
b	0.28	0.45	C2	0.12	0.23
B	1.50	1.70	L	0.35	0.55
B1	2.75	3.05	θ	0°	8°

SOT23-3L

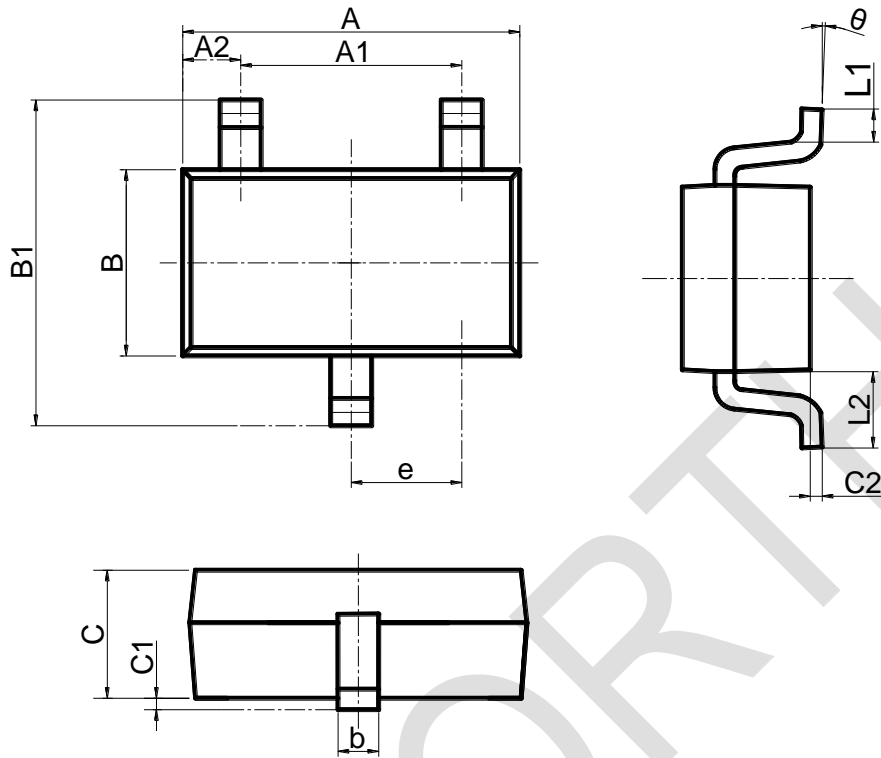

Dimension Symbol	Min (mm)	Max (mm)	Min (inch)	Max (inch)
A	2.820	3.020	0.111	0.119
A1	1.800	2.000	0.071	0.079
B	1.500	1.700	0.059	0.067
B1	2.650	2.950	0.104	0.116
b	0.300	0.500	0.012	0.020
e	0.950(BSC)		0.037(BSC)	
C	1.050	1.250	0.041	0.049
C1	0.000	0.100	0.000	0.004
C2	0.100	0.200	0.004	0.008
L1	0.300	0.600	0.012	0.024
theta	0°	8°	0°	8°

SOT89-5

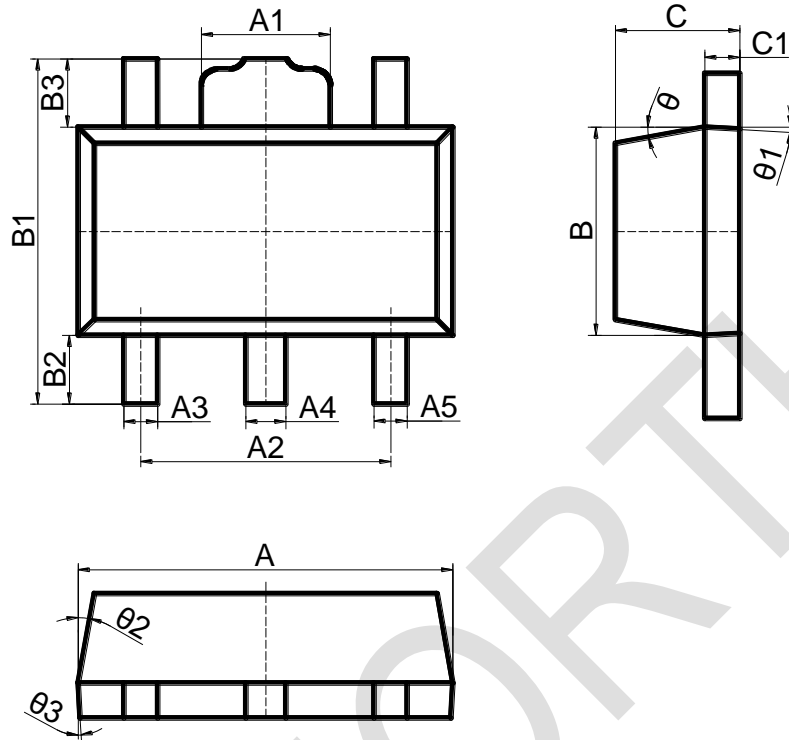

Dimension Symbol	Min (mm)	Max (mm)	Min (inch)	Max (inch)
A	4.400	4.600	0.173	0.181
A1	1.400	1.800	0.055	0.071
A2	2.900	3.100	0.114	0.122
A4	0.360	0.560	0.014	0.022
A5	0.320	0.520	0.013	0.020
B	2.300	2.600	0.091	0.102
B1	3.940	4.250	0.155	0.167
B2	0.900	1.100	0.035	0.043
C	1.400	1.600	0.055	0.063
C1	0.350	0.440	0.014	0.017

SOT-223

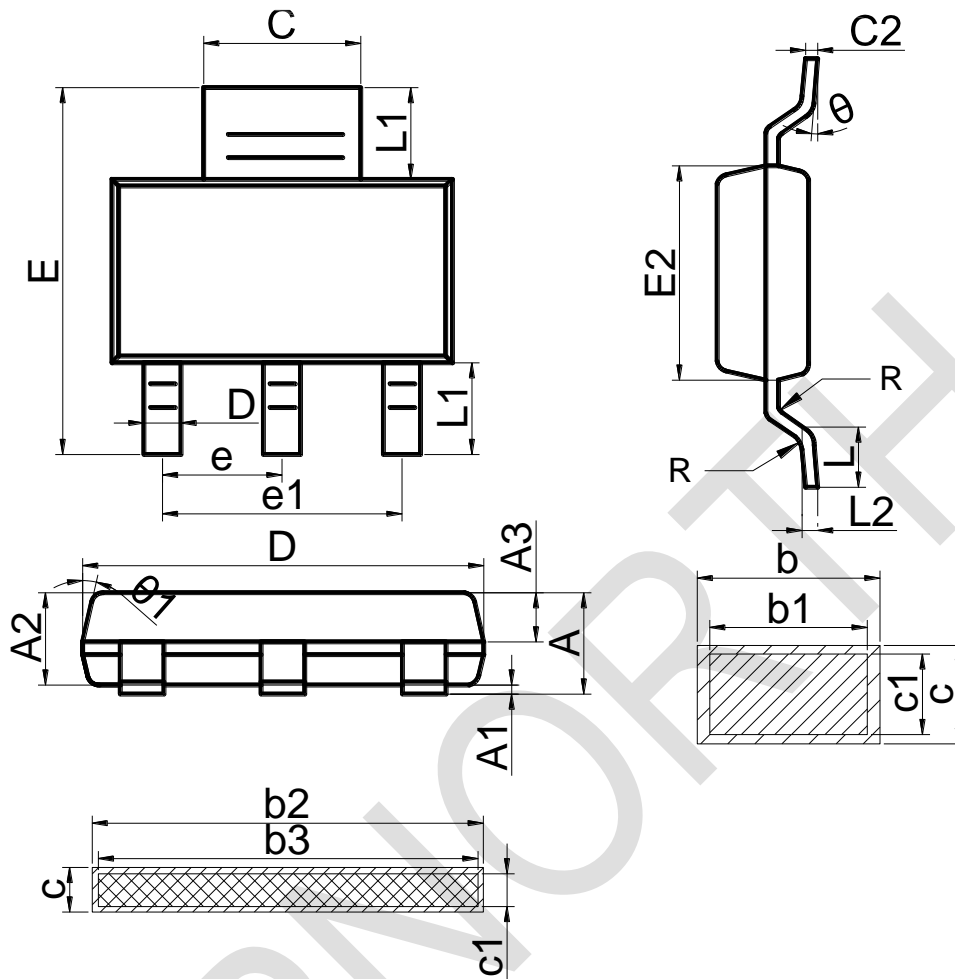

Dimension Symbol	Min (mm)	Nom (mm)	Max (mm)	Dimension Symbol	Min (mm)	Nom (mm)	Max (mm)
A			1.80	E	6.80		7.20
A1	0.02		0.10	R	0.10		
A2	1.50	1.60	1.70	E2	3.33	3.43	3.53
A3	0.80	0.90	1.00	e	2.30(BSC)		
b	0.67		0.80	e1	4.60(BSC)		
b1	0.66	0.71	0.76	L	0.80	1.00	1.20
b2	296		3.09	L1	1.75(REF)		
b3	2.95	3.00	3.05	L2	4.60(BSC)		
c	0.30	6.53	6.58	θ	0°		8°
c1	0.29	0.30	0.31	$\theta1$	10°	12°	14°
D	6.48	6.53	6.58				

TO-252

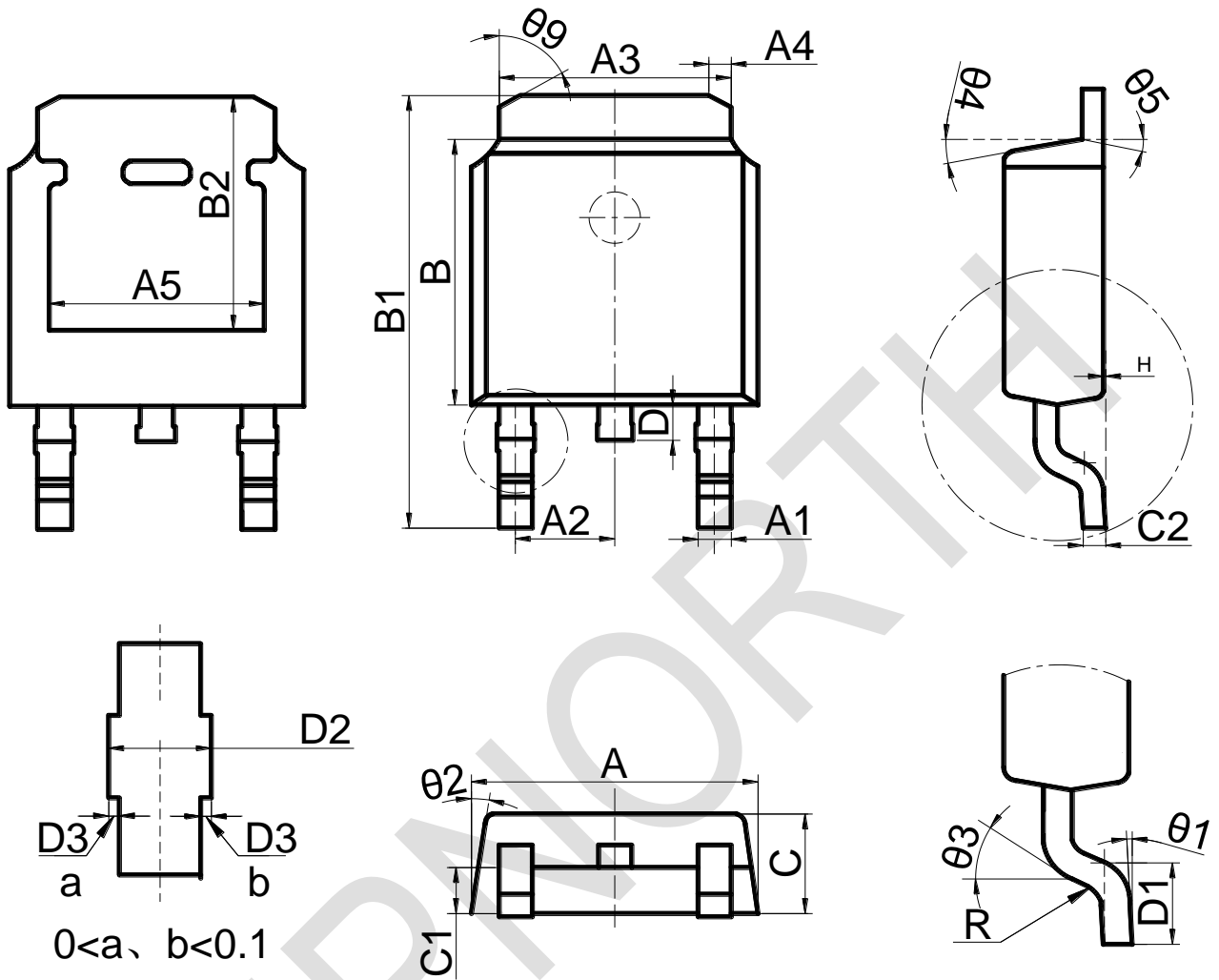

Dimension Symbol	Min (mm)	Nom (mm)	Max (mm)	Dimension Symbol	Min (mm)	Nom (mm)	Max (mm)
A1	0.75		0.84	C1	1.02	1.067	1.12
A2	2.286(BSC)			C2	0.49		0.57
A3	5.30(REF)			C	2.20	2.30	2.40
A5	4.70			D1	1.40	1.50	1.60
A	6.50	6.60	6.79	D2	0.75		0.84
B1	9.90	10.10	10.30	D3	0.01		0.05
B2	5.30(REF)			D	0.60	0.80	1.00
B	6.0	6.10	6.20	θ_1	0		8°

12 Important Statement

Chipnorth Electronic Technology (Nanjing) Co., Ltd. and its subsidiaries reserve the right to make modifications, improvements, corrections, or other changes to this document and to any of the products described herein at any time without notice. Chipnorth Electronic Technology (Nanjing) Co., Ltd. disclaims any liability arising out of the use of this document or any of the products described herein; Chipnorth Electronic Technology (Nanjing) Co., Ltd. does not transfer any license to its patents or trademarks or other rights. Any customer or user using this document or any of the products described herein assumes all risk and agrees to hold harmless Chipnorth Electronic Technology (Nanjing) Co., Ltd. and all companies whose products are displayed on Chipnorth Electronic Technology (Nanjing) Co., Ltd.

Chipnorth Electronic Technology (Nanjing) Co., Ltd. makes no warranty and assumes no responsibility for any products purchased through unauthorized sales channels. In the event that a customer purchases or uses a product from Chipnorth Electronic Technology (Nanjing) Co., Ltd. for any unintended or unauthorized use, the customer shall indemnify and hold harmless Chipnorth Electronic Technology (Nanjing) Co., Ltd. and its representatives from and against all claims, damages, and attorney's fees arising from any personal injury or death, directly or indirectly, arising out of or in connection with such purchase or use.