

## Low Power Linear Regulator with Current

### 1 Description

The LDO is a high-precision low dropout linear regulator with current limiting function, output current up to 300mA, low power consumption, high PSRR, as well as short-circuit protection and over-temperature protection, available in SOT89-3, DFN2X2-6L, SOT-23-5, SOT23-3 and other package forms.

### 2 Features

- Ultra-low quiescent current: 1.2μA
- High accurate: ±2%
- Low dropout voltage: 200mV@I<sub>OUT</sub>=100mA, V<sub>OUT</sub> =5V
- Maximum output current: 300mA
- Input Voltage Range: Max 36V
- Output short circuit protection
- Thermal shutdown

### 3 Applications

- Cell phone
- Battery-powered equipment
- Wireless telephones, wireless telephones, wireless communication equipment
- Camera Recorder
- Portable audio-visual equipment
- Palmtop computer

### 4 Ordering information

Product Number	Package	Quantity/Tape
CN86LXXXDSR	DFN2x2-6	4000/Type
CN86LXXXTCR	SOT23-5	3000/Type
CN86LXXXATCR	SOT23-5	3000/Type
CN86LXXXTGR	SOT23-3	3000/Type
CN86LXXXOGR	SOT89-3	1000/Type
CN86LXXXAOG	SOT89-3	1000/Type

Product Number	Output voltage
CN86L028	V <sub>OUT</sub> =2.8V
CN86L030	V <sub>OUT</sub> =3.0V
CN86L033	V <sub>OUT</sub> =3.3V
CN86L036	V <sub>OUT</sub> =3.6V
CN86L040	V <sub>OUT</sub> =4.0V
CN86L050	V <sub>OUT</sub> =5.0V
CN86L056	V <sub>OUT</sub> =5.6V
CN86L120	V <sub>OUT</sub> =12.0V

### 5 Marking

Product Number	Marking*
CN86LXXXDSR	CN86XX YYWW
CN86LXXXTCR	6XXYW
CN86LXXXATCR	86LXXXA YYWW
CN86LXXXTGR	6XXYW
CN86LXXXOGR	CN86LXXX YYWW
CN86LXXXAOG	CN86LXXXA YYWW

Note: YY=Year WW=Week.

Green (RoHS & HF): CHIPNORTH defines "Green" to mean Pb-Free (RoHS compatible) and free of halogen substances. If you have additional comments or questions, please contact your CHIPNORTH representative directly.

Moisture sensitivity level(MSL):3

## 6 Pinout

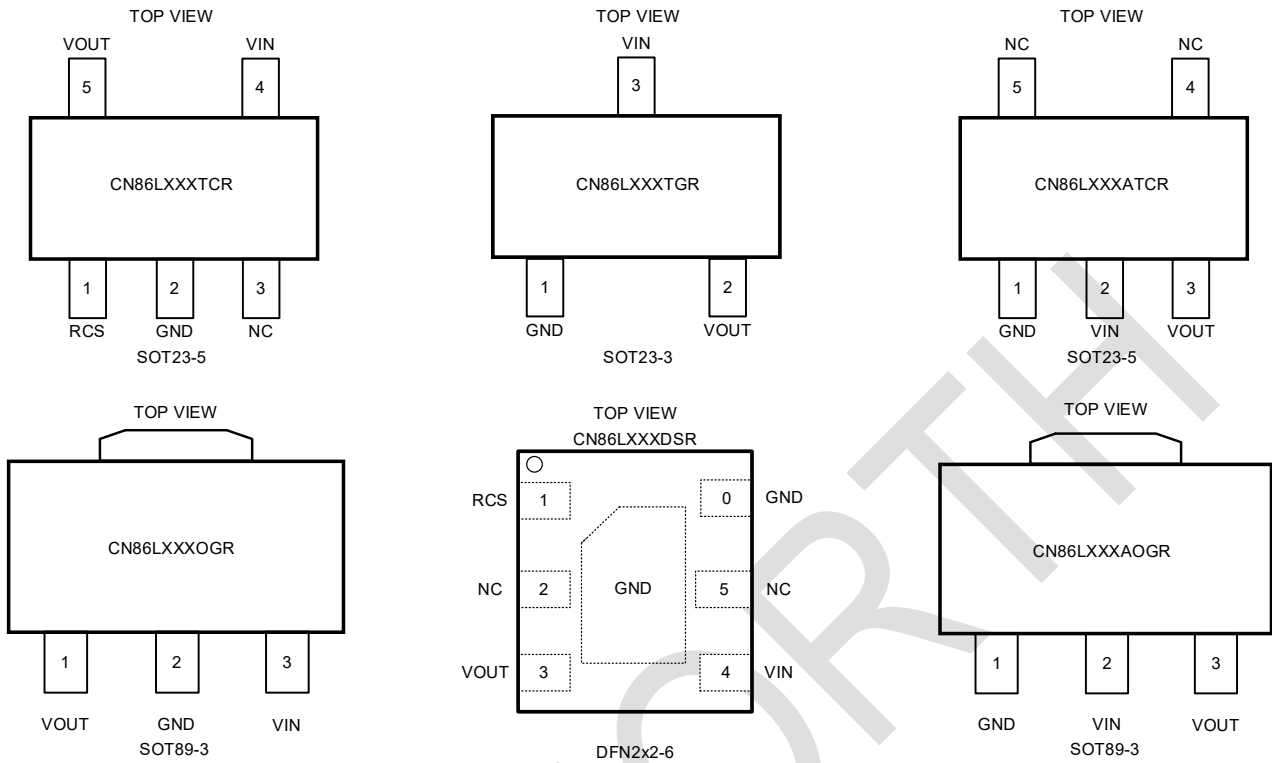

## 7 Typical Application

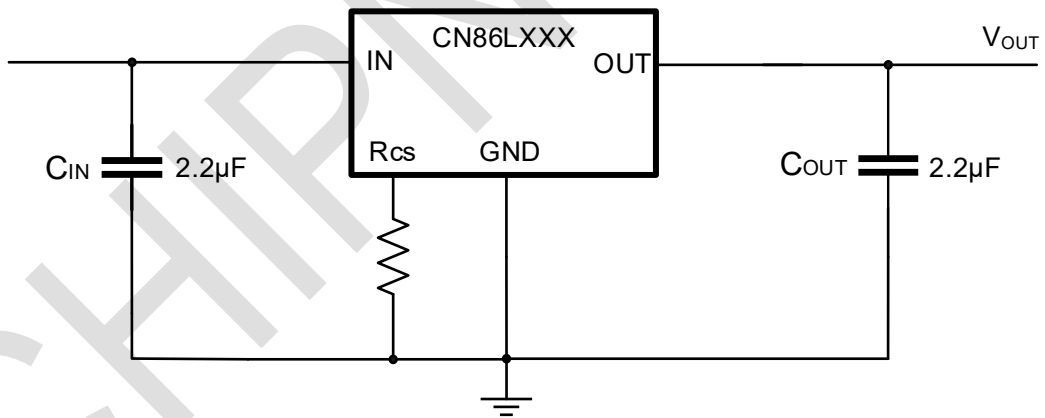

Note: General application circuits are recommended input capacitance  $C_{IN} = 2.2\mu\text{F}$ , near the chip input; output capacitance  $C_{OUT} = 2.2\mu\text{F}$ , near the chip output.

## 8 Block Diagram

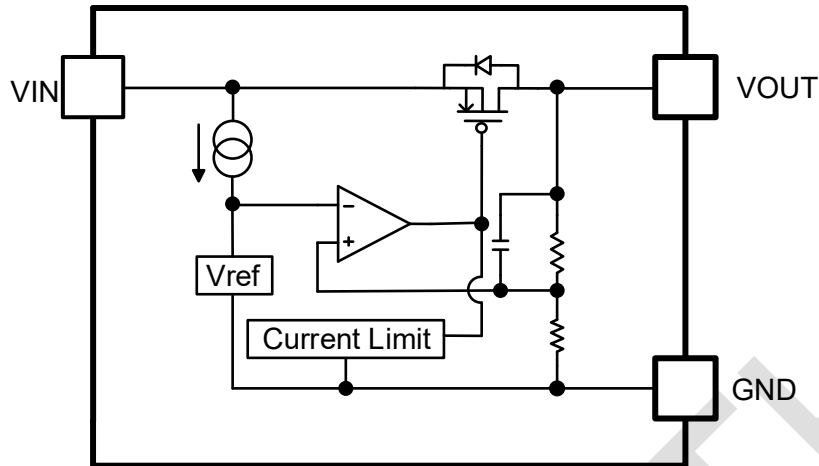

## 9 Pin Descriptions

Pin Name	Pin No.			Descriptions
	CN86LXXX OGR	CN86LXXX AOG R	CN86LXXX ATCR	
GND	2	1	1	GND
VIN	3	2	2	Input
VOUT	1	3	3	Output
NC			4	No Connect
NC			5	No Connect

Pin Name	Pin No.			Descriptions
	CN86LXXX TCR	CN86LXXX TGR	CN86LXXX DSR	
GND	2	1	6	GND
VIN	4	3	4	Input
VOUT	5	2	3	Output
NC	3		2	No Connect
NC			5	No Connect
RCS	1		1	Current limiting regulation

## 10 Specifications

### 10.1 Absolute Maximum Ratings

Parameter	Symbol	Value	Units
Maximum Input Voltage	V <sub>IN</sub>	-0.3 ~ 40	V
Maximum Output Voltage	V <sub>OUT</sub>	-0.3 ~ 40	V
Ambient Temperature (T <sub>A</sub> )	T <sub>A</sub>	125	°C
Storage temperature range	T <sub>STG</sub>	-55 ~ 150	°C
Output Current	I <sub>OUT</sub>	300	mA
Welding temperature	T <sub>LEAD</sub>	260 (Soldering, 10s)	°C

(1) Stresses exceeding the values listed under Absolute Maximum Ratings may cause permanent damage to the device. These listed values are stress ratings only and do not imply that the device will operate properly under these conditions or any other conditions other than the recommended operating conditions. Prolonged operation at maximum absolute rating conditions can affect device reliability.

(2) All voltage values are based on the ground terminal.

### 10.2 ESD Ratings

Discharge mode	Standardize	Value	Units
HBM	ESDA/JEDEC JS-001-2017	±4000	V
CDM	ESDA/JEDEC JS-002-2018	±2000	V

### 10.3 Recommended Operating Ran

Parameter	Symbol	Min.	Max.	Units
Input Voltage Range	V <sub>IN</sub>	V <sub>OUT</sub> +1	36	V
Working environment temperature	T <sub>A</sub>	-40	105	°C

### 10.4 Thermal Information

Parameter	Package	Value	Units
Junction to ambient thermal resistance (R <sub>θJA</sub> )	SOT23-3	220	°C/W
	SOT23-5	188	°C/W
	DFN2x2-6	140	°C/W
	SOT89-3	100	°C/W

## 10.5 Electrical Characteristics

Test conditions:  $V_{IN}=V_{OUT}+1V$ ,  $C_{IN}=2.2\mu F$ ,  $C_{OUT}=2.2\mu F$ ,  $T_A=25^\circ C$ , unless otherwise specified.

Parameter	Symbol	Conditions	Min	Typ	Max	Units
Input voltage range	$V_{IN}$	$I_{OUT}=10mA$	$V_{OUT}+0.1V$		36	V
Output voltage	$V_{OUT}$	$V_{IN}=V_{OUT}+2V$ , $I_{OUT}=10mA$	$V_{OUT}$ $\times 0.98$	$V_{OUT}$	$V_{OUT}$ $\times 1.02$	V
Output voltage accuracy	$V_{OUT}\%$	$V_{IN}=V_{OUT}+2V$ , $I_{OUT}=10mA$	98%		102%	
Line regulation	$\frac{\Delta V_{OUT}}{\Delta V_{IN} \cdot V_{OUT}}$	$V_{IN}=V_{SET}+1V \sim 12V$ $I_{OUT}=3mA$ ( $V_{OUT}=5V$ )		0.011	0.067	%/V
Load regulation	$\Delta V_{OUT}$	$V_{IN}=V_{SET}+1V$ $I_{OUT}=3 \sim 300mA$		52	100	mV
Quiescent current	$I_Q$	$V_{IN}=12V$ , $I_{OUT}=0mA$	0.2	1.2	3	$\mu A$
Dropout voltage <sup>*1</sup>	$V_{DROP}$	$I_{OUT}=100mA @ V_{OUT}=5V$	0.1	0.2	0.3	V
Maximum output current	$I_{OUT\_MAX}$	$V_{OUT}=0.95 \cdot V_{OUT(S)}$	300			mA
Current limit	$I_{LIMIT}$		300	500	700	mA
OTP threshold		95% rated $V_{OUT}$		160		$^\circ C$
OTP hysteresis				30		$^\circ C$
PSRR		100Hz, $I_{OUT}=50mA$		50		dB

Note\*:

$V_{DROP}=V_{IN}-(V_{OUT\_REG} \cdot 0.98)$ ,  $V_{OUT\_REG}$  is the output voltage when  $V_{IN}=V_{OUT}+1.0V$  and  $I_{OUT}=100mA$ .  $V_{IN}$  is the input voltage, and when the input voltage decreases gradually, the output voltage becomes 98% of  $V_{OUT\_REG}$ .

## 10.6 Characteristics Curve (CN86L033OGR)

Test conditions:  $V_{IN}=V_{OUT}+1V$ ,  $C_{IN}=2.2\mu F$ ,  $C_{OUT}=2.2\mu F$ ,  $T_A=25^\circ C$ , unless otherwise specified.

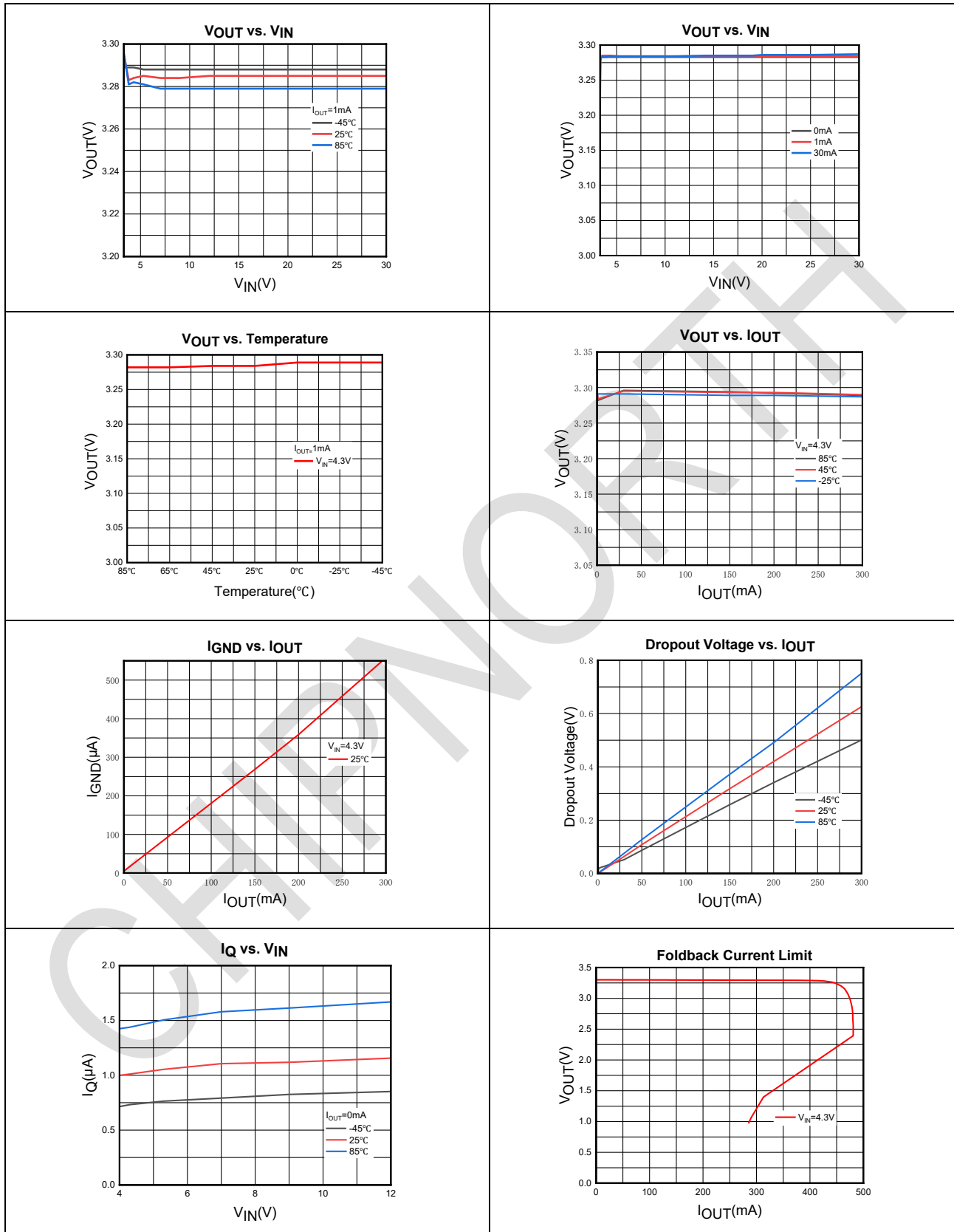

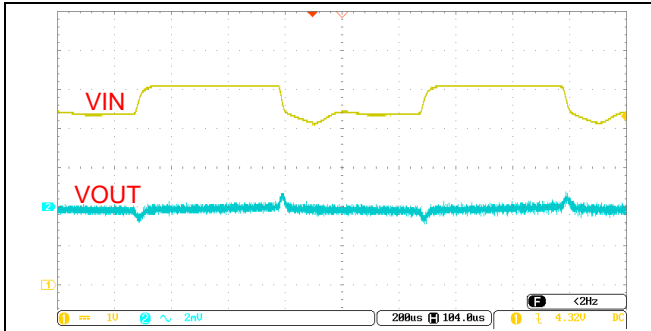

Figure 1 Line Transient  
( $V_{IN}$ =from 4.3V to 5V to 4.3V,  $I_{OUT}$ =0mA)



Figure 2 Line Transient  
( $V_{IN}$ =from 4.3V to 5V to 4.3V,  $I_{OUT}$ =300mA)

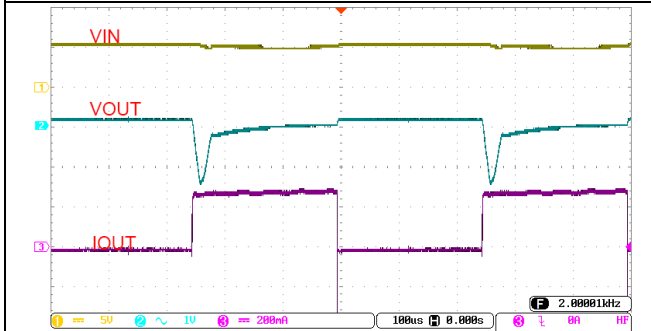

Figure 3 Load Transient  
( $V_{IN}$ =5.3V,  $I_{OUT}$ =0mA-300mA-0mA)

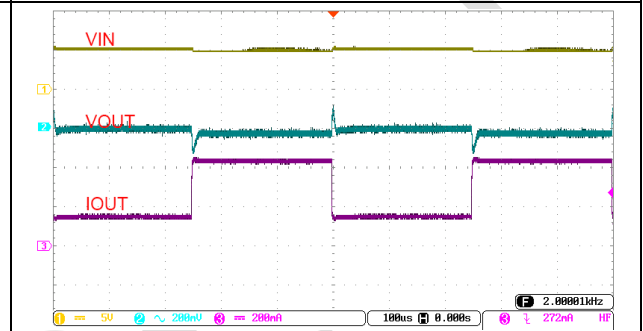

Figure 4 Load Transient  
( $V_{IN}$ =5.3V,  $I_{OUT}$ =150mA-300mA-150mA)

CHIPNORTH

## 11 Functional Description

### 11.1 Current Folding

CN86L has a current foldback function, after triggering the current limit protection, the output current remains constant and the output voltage decreases as the load impedance decreases, this function can be used as both current limit protection and short circuit protection.

### 11.2 RCS Pin Function

The RCS pin is used to control the chip current limit. The details are as follows:

- 1、 When the RCS pin is floating, the current limit is 500mA.
- 2、 When RCS pin is short-circuited, the current limit is 500mA.
- 3、 When RCS is connected to a resistor, the current limit is determined by the resistor, when  $R_{CS} < 2.63K$ , the current limit is 500mA. when  $R_{CS} > 2.63K$ , the current limit is determined by the following formula:

$$I_{Limit} (mA) = \frac{1460}{R_{CS}(k\Omega)}$$

### 11.3 Thermal shutdown

The CN86L has an internal thermal shutdown function. When the internal junction temperature of the chip exceeds 160°C, the upper and lower tubes will stop switching to reduce the junction temperature, and the chip will restart softly when the junction temperature is reduced to 130°C or below.

## 12 Package Information

### SOT89-3

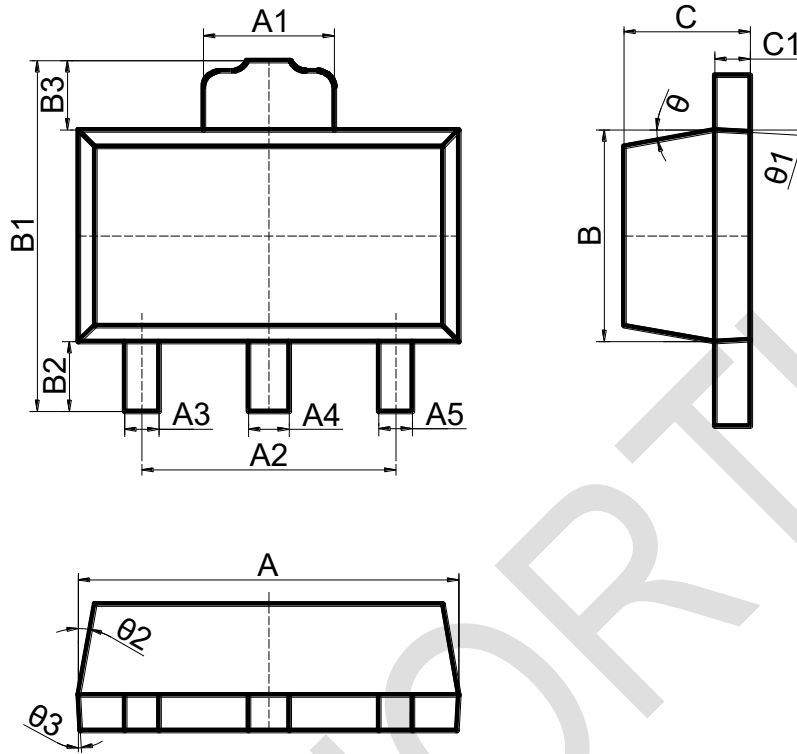

Dimension Symbol	Min (mm)	Nom (mm)	Max (mm)
A	4.4	4.5	4.6
A1	1.4	1.6	1.8
A2	2.8	3.0	3.2
A4	0.37	0.47	0.57
A5	0.22	0.42	0.62
B	2.4	2.5	2.6
B1	-	-	4.25
B2	0.8	-	-
C	1.4	1.5	1.6
C1	0.3	0.4	0.5

DFN2x2-6

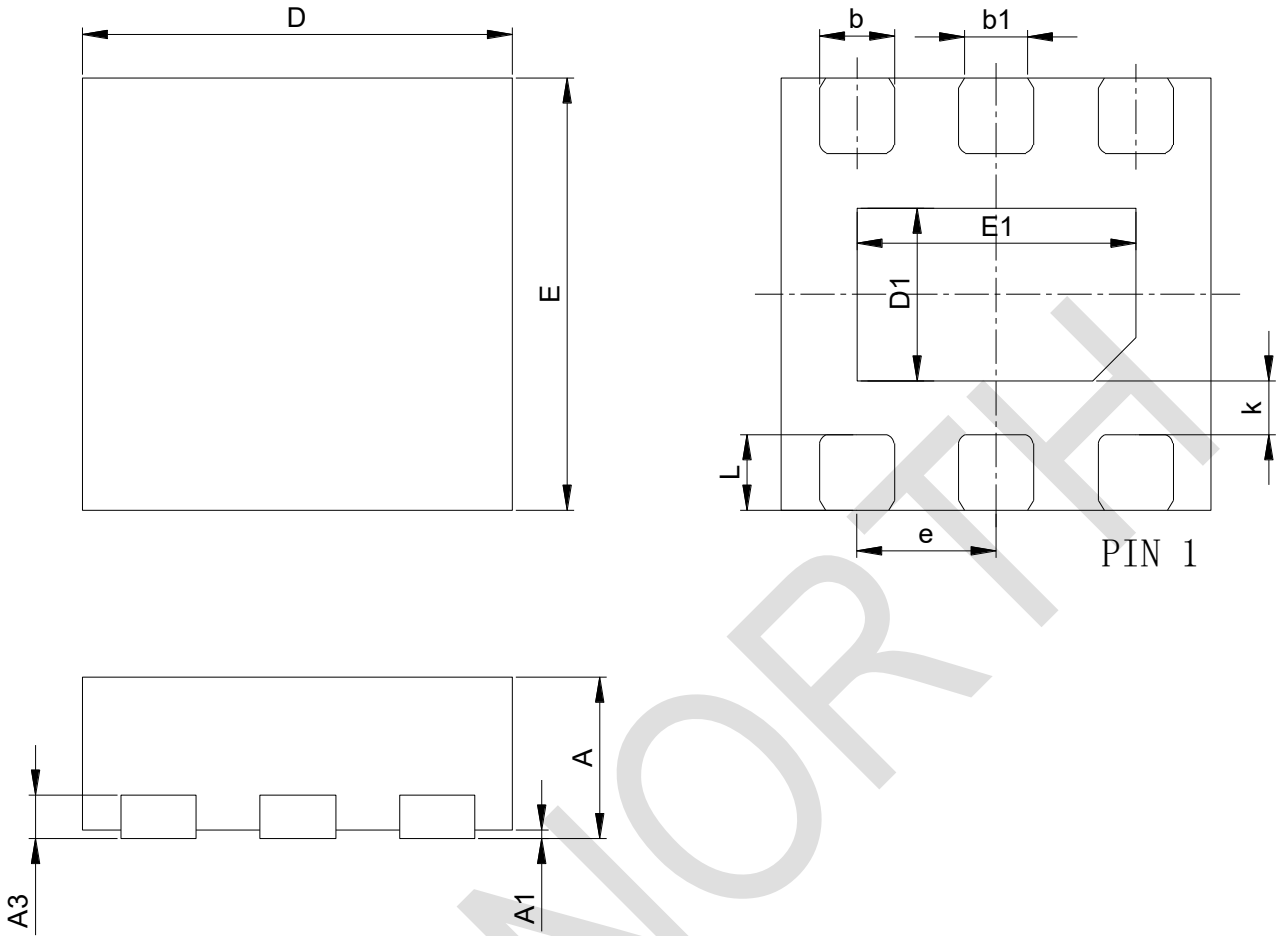

Dimension Symbol	Min (mm)	Nom (mm)	Max (mm)	Dimension Symbol	Min (mm)	Nom (mm)	Max (mm)
A	0.7	0.75	0.8	E1	1.5	1.6	1.7
A1	0	0.025	0.05	k	0.25REF		
A3	0.203REF			b	0.25	0.3	0.35
D	1.9	2.0	2.1	b1	0.22REF		
E	1.9	2.0	2.1	e	0.65REF		
D1	0.9	1.0	1.1	L	0.2	0.25	0.3

SOT23-5

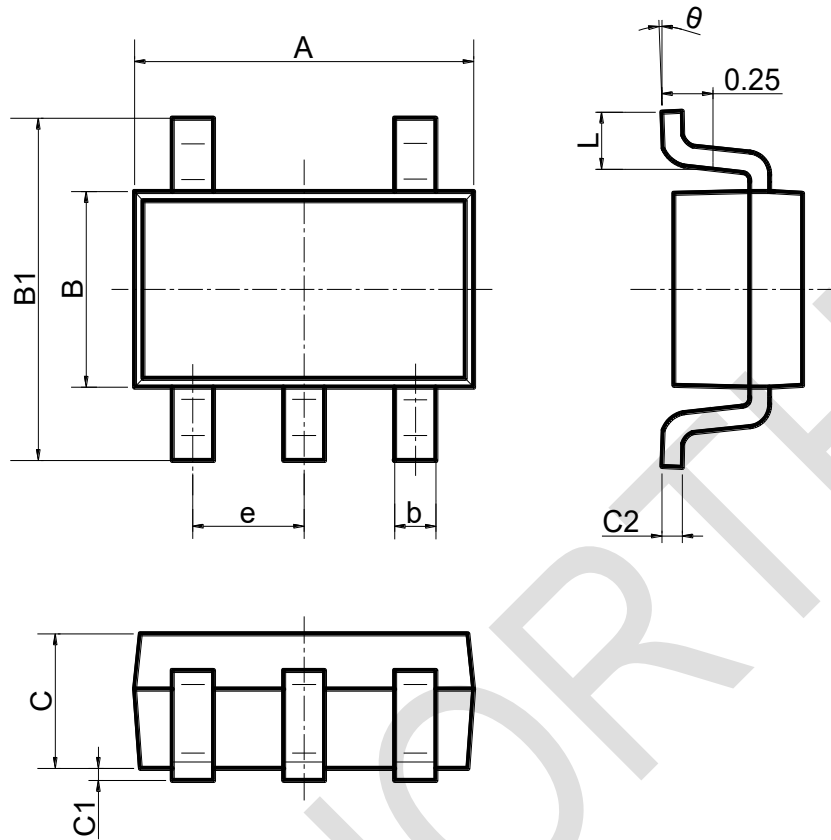

Dimension Symbol	Min (mm)	Max (mm)	Dimension Symbol	Min (mm)	Max (mm)
A	2.82	3.02	C	1.05	1.15
e	0.95(BSC)		C1	0.03	0.15
b	0.28	0.45	C2	0.12	0.23
B	1.50	1.70	L	0.35	0.55
B1	2.75	3.05	θ	0°	8°

SOT23-3L

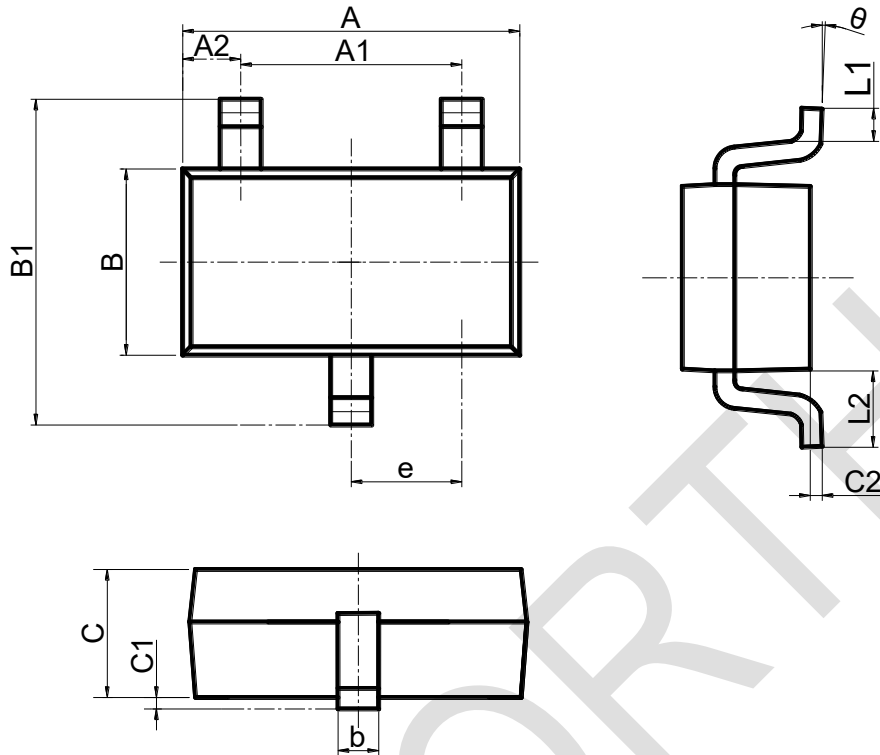

Dimension Symbol	Min (mm)	Max (mm)	Min (inch)	Max (inch)
A	2.820	3.020	0.111	0.119
A1	1.800	2.000	0.071	0.079
B	1.500	1.700	0.059	0.067
B1	2.650	2.950	0.104	0.116
b	0.300	0.500	0.012	0.020
e	0.950(BSC)		0.037(BSC)	
C	1.050	1.250	0.041	0.049
C1	0.000	0.100	0.000	0.004
C2	0.100	0.200	0.004	0.008
L1	0.300	0.600	0.012	0.024
$\theta$	0°	8°	0°	8°

### 13 Important Statement

Chipnorth Electronic Technology (Nanjing) Co., Ltd. and its subsidiaries reserve the right to make modifications, improvements, corrections, or other changes to this document and to any of the products described herein at any time without notice. Chipnorth Electronic Technology (Nanjing) Co., Ltd. disclaims any liability arising out of the use of this document or any of the products described herein; Chipnorth Electronic Technology (Nanjing) Co., Ltd. does not transfer any license to its patents or trademarks or other rights. Any customer or user using this document or any of the products described herein assumes all risk and agrees to hold harmless Chipnorth Electronic Technology (Nanjing) Co., Ltd. and all companies whose products are displayed on Chipnorth Electronic Technology (Nanjing) Co., Ltd.

Chipnorth Electronic Technology (Nanjing) Co., Ltd. makes no warranty and assumes no responsibility for any products purchased through unauthorized sales channels. In the event that a customer purchases or uses a product from Chipnorth Electronic Technology (Nanjing) Co., Ltd. for any unintended or unauthorized use, the customer shall indemnify and hold harmless Chipnorth Electronic Technology (Nanjing) Co., Ltd. and its representatives from and against all claims, damages, and attorney's fees arising from any personal injury or death, directly or indirectly, arising out of or in connection with such purchase or use.